



# Scanner User's Guide

## MobileOffice S410 Plus



## **Trademarks**

© 2021 Plustek Inc. All rights are reserved. No portion of this document may be reproduced without permission.

Plustek is a registered trademark of Plustek Inc. OCR processing by ABBYY® FineReader®, © 2021 ABBYY. ABBYY and FineReader are trademarks of ABBYY Software, Ltd. which may be registered in some jurisdictions.

All trademarks and brand names mentioned in this publication are property of their respective owners.

## **Liability**

While all efforts have been made to ensure the accuracy of all contents in this manual, we assume no liability for errors or omissions or by statements of any kind in this manual, whether such errors are omissions or statements resulting from negligence, accidents, or any other cause. The contents of this manual are subject to change without notice. We will not shoulder any legal liability, if users failed to follow the operation instructions in this manual.

## **Copyright**

The scanning of certain documents, for example checks, bank notes, I.D. cards, government bonds, or public documents, may be prohibited by law and/or subject to criminal prosecution. We recommend you to be responsible and respectful of the copyrights laws when you are scanning books, magazines, journals and other materials.

## **Environmental Information**

Recycle or disposal at end-of-life information, please ask local distributors or suppliers for recycle and disposal information. The product is designed and produced to achieve sustainable environmental improvement. We strive to produce products in compliance with global environmental standards. Please consult your local authorities for proper disposal.

The product packaging is recyclable.

Attention for recycling (For EU country only)

Protect your environment! This product should not be thrown into the household waste container. Please give it to the free collecting center in your community.

## **Screen Examples in This Manual**

The screen shots in this guide were made with Windows 10. If you are using Windows 8 / 7, your screen will look somewhat different but function the same.

# Table of Contents

<b>INTRODUCTION</b> .....	<b>1</b>
How to Use This Guide.....	1
Conventions of This Guide.....	1
<i>A Note about Icons</i> .....	2
Safety Precautions.....	2
System Requirements.....	3
Box Contents.....	3
Scanner Overview.....	4
<b>CHAPTER I. INSTALLING THE SCANNER</b> .....	<b>5</b>
Software Installation Requirements.....	5
Hardware Requirements.....	5
Installing and Setting up the Scanner.....	6
<i>Step 1. Connecting the Scanner to Your Computer</i> .....	6
<i>Step 2. Installing the Software</i> .....	6
<i>Step 3. Testing the Scanner</i> .....	9
Installing Additional Software.....	9
<b>CHAPTER II. SCANNING</b> .....	<b>10</b>
Using the Scanner.....	10
<i>Card Scanning</i> .....	10
<i>Document Scanning</i> .....	11
Scanning Methods.....	12
<i>Scanning via TWAIN Interface</i> .....	12
<i>Scanning from iDoc</i> .....	13
<b>CHAPTER III. CLEAN AND MAINTENANCE</b> .....	<b>16</b>
Clean the Scanner.....	16
<i>Cleaning Materials</i> .....	16
<i>Clean Feed Roller and Glass</i> .....	17
Calibrating the Scanner.....	18
Power Save.....	19
Usage & Maintenance Tips.....	19
<b>CHAPTER IV. TROUBLESHOOTING</b> .....	<b>20</b>
Scanner Connection.....	20
<b>APPENDIX A: SPECIFICATIONS</b> .....	<b>21</b>
<b>APPENDIX B: CUSTOMER SERVICE AND WARRANTY</b> .....	<b>22</b>
Service & Support Information (For EU country only).....	22
Statement of Limited Warranty.....	23
FCC Radio Frequency Statement.....	24

# Introduction

Thank you for choosing us as your scanner supplier. Your new scanner will improve the professionalism of your day-to-day computing tasks by allowing you to input images and electronic text into your computer system. You can easily scan single-sided documents with your scanner.

Like all of our products, your new scanner is thoroughly tested and backed by our reputation for unsurpassed dependability and customer satisfaction. We hope you will continue to turn to us for additional quality products as your computing needs and interests grow.

## How to Use This Guide

---

This User's Guide provides instructions and illustrations on how to install and operate your scanner. This guide assumes the user is familiar with Microsoft Windows. If this is not the case, we suggest you learn more about Microsoft Windows by referring to your Microsoft Windows manual before using your scanner.

The Introduction section of this manual describes the box contents and minimum computer requirements to use this scanner. Before you start installing your scanner, check the box contents to make sure all parts are included. If any items are damaged or missing, please contact the vendor where you purchased your scanner or our customer service directly.

Chapter I describes how to install scanner's software and connect the scanner to your computer. Note: The scanner connects to your computer through the Universal Serial Bus (USB). If your computer does not support USB technology, you will need to purchase a USB interface card to add USB capabilities to your computer, or buy and install USB connectors if your motherboard has USB capabilities. This guide assumes that your computer is USB-ready and has a free USB port.

Chapter II describes how to use your scanner.

Chapter III describes how to maintain and clean your scanner.

Chapter IV contains technical support information that can help you solve simple problems.

Appendix A contains the specifications of the scanner you purchased.

Appendix B contains our customer service, the limited warranty agreement and FCC statement concerning the product.

## Conventions of This Guide

---

**Bold** — Important note or first use of an important term in a chapter.

"XXX" — Represents commands or contents on your computer screen.

## A Note about Icons

This guide uses the following icons to point out information that deserves special attention.



**Warning**

A procedure that must be followed carefully to prevent injury, or accidents.



**Attention**

Instructions that are important to remember and may prevent mistakes.



**Information**

Optional tips for your reference.

## Safety Precautions

---

Before using this device, please read the following important information to eliminate or reduce any possibility of causing damage and personal injury.

1. Usage, the product is for indoor use in dry locations. Moisture condensation may occur inside this device and cause malfunction at these conditions:
  - when this device is moved directly from a cold to a warm location;
  - after a cold room is heated;
  - when this device is placed in a damp room.

To avoid the moisture condensation, you are recommended to follow the procedure:

- i. Seal this device in a plastic bag for it to adapt to room conditions.
  - ii. Wait for 1-2 hours before removing this device from the bag.
2. Do not use the USB cable provided with the scanner. Use of other cable may lead to malfunction.
  3. Avoid using the scanner in a dusty environment. Dust particles and other foreign objects may damage the unit.
  4. Do not subject the scanner to excessive vibration. It may damage the internal components.
  5. Unplug this device if you don't need to use for a certain period of time, such as, during night or long weekend, to avoid any risks of causing fire.
  6. Do not attempt to disassemble the scanner. There is danger of an electrical shock and opening your scanner will void your warranty.

## System Requirements<sup>1</sup>

---

- 2.0 GHz CPU with dual-core processor minimum (Recommended: 2.8 GHz Intel® Core™ i5 Processor with 4 CPU Cores or better)
- 4 GB RAM minimum (Recommended: 8 GB or more)
- 2 GB of hard-disk space for program installation
- Display dimensions of 1024x768 or greater
- Operating System: Windows 7 / 8 / 10

## Box Contents<sup>2</sup>

---

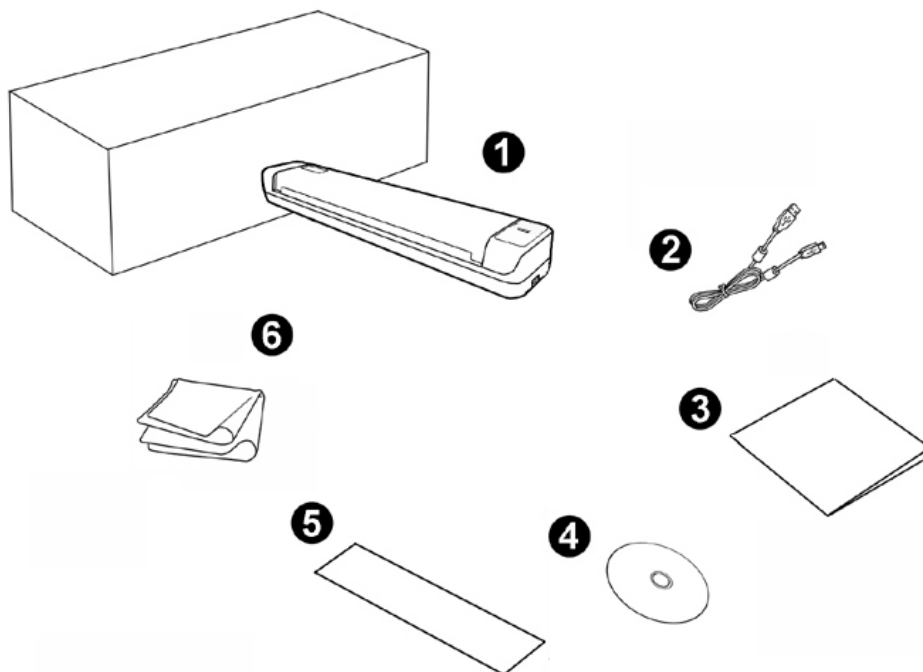

1. Scanner
2. USB Cable
3. Quick Guide
4. Setup / Application DVD-ROM
5. Calibration Sheet
6. Cleaning Cloth

---

<sup>1</sup> Higher requirements might be needed when scanning or editing a large quantity of image data. The system requirements here are only a guideline, as in general the better the computer (motherboard, processor, hard disk, RAM, video graphic card), the better the results.

<sup>2</sup> Save the box and packing materials in case you need to transport this scanner in the future. The product packaging can be recycled.

# Scanner Overview

---

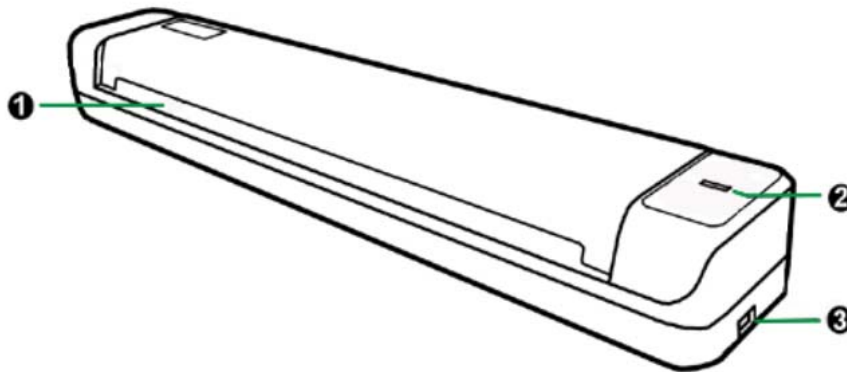

1. **Page feed slot:** Feed the document into the scanner from this direction. You can feel the document being grabbed by the scanner.

2. **LED indicator:** It indicates the scanner's current status.

Light	Status
On	The scanner is connected with the computer, ready to scan images.
Off	The scanner is off, either because of disconnection with the computer, or because the computer is turned off.

3. **USB port:** It connects the scanner to a USB port on your computer by the included USB cable.

# Chapter I. Installing the Scanner

Before installing your scanner, please verify that you have all of the proper components. A list of the package contents is provided in the *Box Contents* section of this guide.

## Software Installation Requirements

Your scanner comes with OCR software (ABBYY FineReader Sprint), the scanner's driver and iDoc. All of these software applications use approximately 800 megabytes of hard disk space after they are installed into your computer. To ensure ample room for the installation, as well as for scanning and saving images, a minimum of 2 GB of hard disk space is recommended.

This USB scanner can only operate under the Microsoft Windows 7 / 8 / 10 operating system.

## Hardware Requirements

This scanner connects to your computer through the Universal Serial Bus (USB), which supports **hot swap**. To determine whether your computer is USB-capable, you must check the rear of your PC to locate a USB jack that looks the same as the one pictured below. Note that on some computers, the USB port at the rear of the computer may be occupied and additional ports may be found on the monitor or keyboard. If you are having trouble in locating the USB port on your computer, please refer to the hardware manual that came with your computer.

Upon examination, you should find one or two rectangular USB ports, which usually appear as shown below.

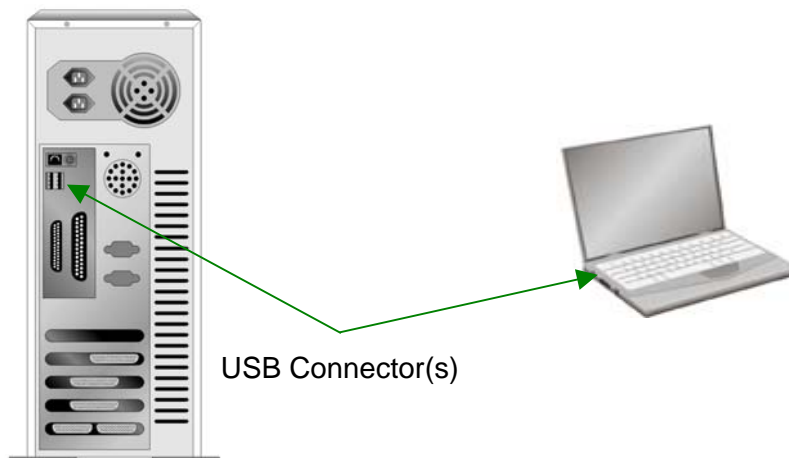

If you don't find such USB ports on your computer, then you need to purchase a certified USB interface card to add USB capabilities to your computer.



# Installing and Setting up the Scanner

Please follow the step-by-step procedures described below to install the Plustek scanner.

## Step 1. Connecting the Scanner to Your Computer

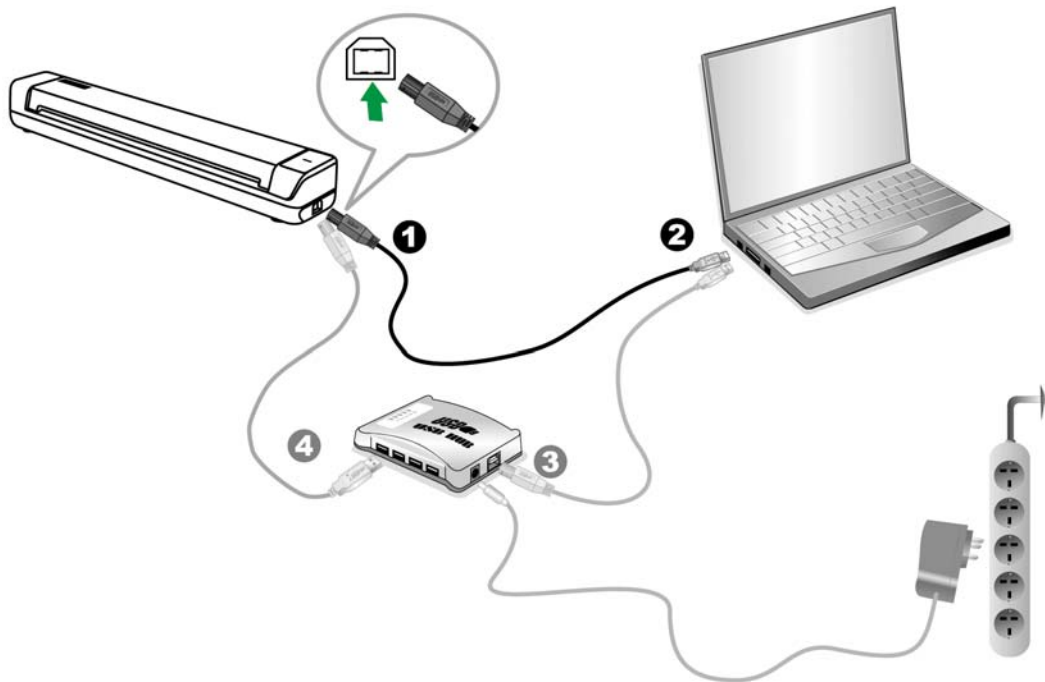

1. Plug the square end of the included USB cable to the USB port of the scanner.
2. Plug the rectangular end of the USB cable to the USB port on the back of your computer.

Note: If there is another USB device connected to the computer, connect the scanner to an available USB port.

3. If you plan to connect your scanner to a USB hub<sup>3</sup>, make sure that the hub is connected to the USB port in your computer. Next, connect the scanner to the USB hub.

Note: If you do not have a USB port available, you might need to buy a USB port.

## Step 2. Installing the Software

1. If the USB components on your computer are functioning correctly, they will automatically detect the scanner causing the “Add New Hardware Wizard” or “Found New Hardware Wizard” to be launched.

Note: If your computer was off when you connected the scanner, the “Add New

---

<sup>3</sup> The USB hub is not included with the scanner. If using a hub, you are recommended to use a hub with its own external power adapter.

Hardware Wizard” message will be displayed when you turn the computer on and when Windows starts.

2. For Windows 7:

When the Setup/Application DVD is for several scanner models

- a. Insert the Setup/Application DVD-ROM, included with your scanner, into your DVD-ROM drive. Click Run install.exe in the "AutoPlay" window.
- b. Click on the "Yes" button if the "User Account Control" dialog pops up. Follow the instructions in the pop-up installation message.
- c. In the "Device Manager" window, right-click on this scanner under "Other devices" and select "Update Driver Software" from the pop-up menu. Click "Browse my computer for driver software" in the window that appears, and click the "Browse" button.
- d. In the "Browse For Folder" window, select the folder or the DVD-ROM drive that contains this scanner driver and click the "OK" button to return to the previous screen. Click the "Next" button and click "Install this driver software anyway" if the "Windows Security" window appears.. Afterwards, please skip to procedure 4.

When the Setup/Application DVD is for one scanner model

- a. Insert the Setup/Application DVD-ROM, included with your scanner, into your DVD-ROM drive. Click Run install.exe in the "AutoPlay" window.
- b. Click on the "Yes" button if the "User Account Control" dialog pops up. Afterwards, please skip to procedure 4.

3. For Windows 8 & Windows 10:

- a. Insert the Setup/Application DVD-ROM, included with your scanner, into your DVD-ROM drive. Click on the pop-up notification, then click "Run install.exe" in the pop-up window. If you miss the pop-up notification, please eject and re-insert the Setup/Application DVD-ROM.
- b. Click on the "Yes" button if the "User Account Control" dialog pops up. Afterwards, please skip to procedure 4.

4. Follow the on-screen instructions to install all software that your new USB scanner requires. If the pop-up wizard window appears click "Next", and click "Install this driver software anyway" in the "Windows Security" window then click "Finish" in the wizard window.

5. After the software is installed, you will be prompted to perform the scanner calibration.

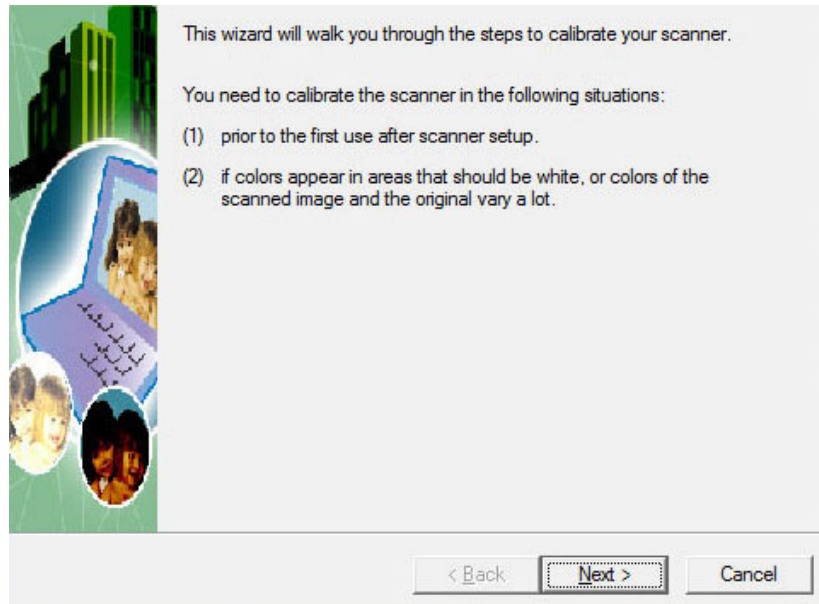

6. Insert the special calibration sheet, included with the scanner, face up into the page feed of the scanner.

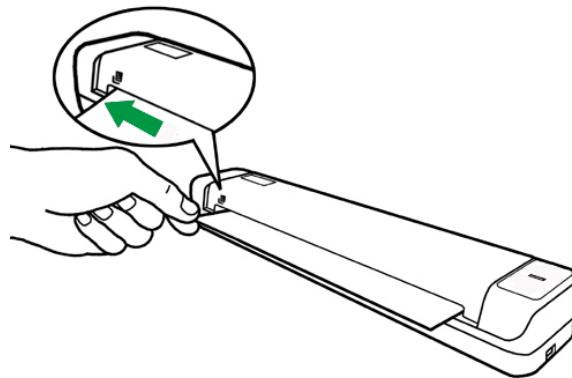

7. Follow the on-screen instructions to complete the scanner calibration.
8. After the installation is complete, close all open applications and click on the "Finish" button to restart your computer.



**Information**

Alternatively you may also use any plain white sheet of paper sized in Letter size (8.5" x 11.69") instead; however, the calibration effect may be less good than the special calibration sheet.





**Attention**

- Save the Setup/Application DVD in case you need to reinstall the driver and software in the future.
- Save the Calibration Sheet in case you need to calibrate the scanner in the future.

## Step 3. Testing the Scanner

The following test procedure checks to see if the scanner is properly functioning with your computer and the scanning software. Before testing your scanner, double check to make sure that all connections are securely fastened.

**To properly test your scanner, please perform the following steps:**

1. Do one of the following to open the **iDoc** window:
  - Click on the **iDoc** shortcut from the Windows **Start** menu > **All Programs** > **Plustek iDoc** folder. (For Windows 8.1 users: Point your mouse cursor to the upper or lower right corner of your screen to open the **Charm** bar. Click on the **Start** charm, then click on the downwards arrow button in the lower left corner of the screen. The **Apps** screen will be shown. Move your cursor to the right edge of the screen to scroll right until you find **Plustek iDoc**, and then click on **iDoc**.) Right-click the  **iDoc** icon in the system tray, and select **iDoc** from the pop-up menu to display the main window.
  - Double-click the icon  on the desktop. Right-click the  **iDoc** icon in the system tray, and select **iDoc** from the pop-up menu to display the main window.
2. Insert the document face up into the scanner. Please allow the sensor to detect the edges of your document. The scanning starts immediately.

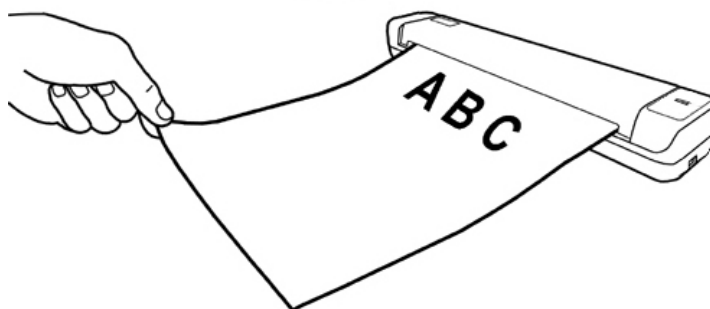

3. If an image appears on your screen, your scanner is working properly.

## Installing Additional Software

---

Your scanner is TWAIN compliant and functions with virtually all available TWAIN compatible software. If you purchase additional software to be used with your scanner, please make sure that it conforms to the TWAIN standard.

# Chapter II. Scanning

Your scanner needs to be driven by certain type of software program. Since all documents or images (whether text or pictures) that are acquired from the scanner are treated by your computer as images, most scanning will probably be done from an image-editing program where you can view, edit, save and output the scanned images.

What about scanning text documents and editing them in a word processor? This is the role of Optical Character Recognition (OCR) software. OCR software converts the image files that are created from scanning text documents into text files that can be viewed, edited and saved by word processors. An OCR program has also been bundled on the included Setup/Application DVD-ROM, and if you wish to use the scanner in this way you should install the OCR software that is included.

The iDoc program, seamlessly integrating the operation of your scanner with your computer and other peripherals, provides a quick and convenient way to perform various scanning functions.

Please refer to the online help of each program to guide you through any questions you may have while scanning within that program.

## Using the Scanner

### Card Scanning

This is the special design for plastic card scan. Plastic cards include: driver license, ID card, medical insurance card or any membership cards.

#### Plastic card scanning

The plastic card can be driver license, ID card, insurance card, medic-care card or any membership card.



**Attention**

- Make sure the plastic card you wish to scan is horizontally loaded into the scanner.
- Maximum thickness of each plastic card is: Non-Embossed 1.0 mm.

To scan the plastic card, please follow the steps:

1. Insert one plastic card face up into the scanner.

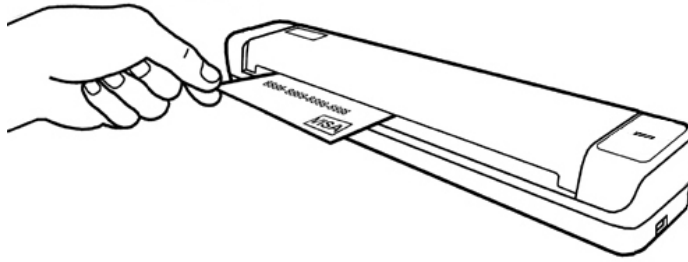

2. The scanning starts immediately.

## Business card scanning

---



### Attention

Make sure the business card you wish to scan is horizontally loaded into the scanner.

---

To scan the business card, please follow the steps:

1. Insert one business card face up into the scanner.

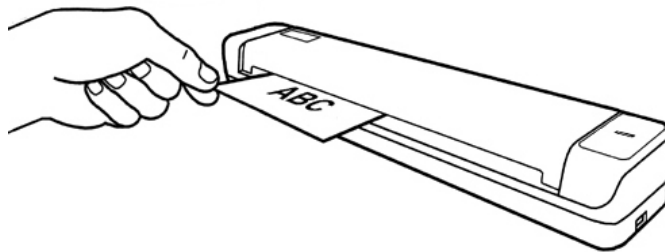

2. The scanning starts immediately.

## Document Scanning

Actually, document scanning is similar with the card scanning, however, we'll describe the steps simply for you:

1. Insert one-document face up into the scanner.

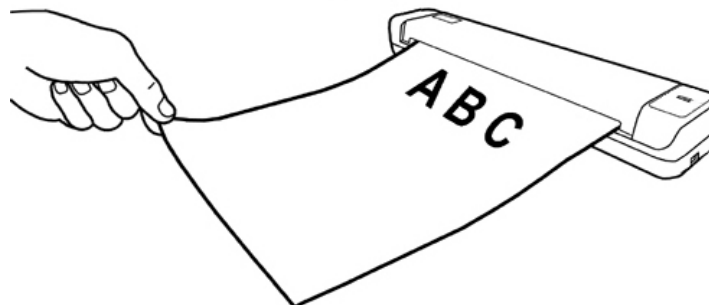

2. The scanning starts immediately.

## Scanning Methods

---

The TWAIN interface and iDoc software are automatically installed to your system along with the scanner driver.



**Attention**

---

Before you start scanning, check the following:

1. The power of both your computer and scanner is turned on.
  2. The icon  appears on the Windows system tray.
  3. Paper is appropriately loaded into the scanner.
- 

## Scanning via TWAIN Interface

The TWAIN program is a very important piece of software that comes with your scanner. This program acts as an interface between the scanner hardware and the image-editing software you are using to view and edit images. The TWAIN program allows you to adjust a number of settings to define the quality of the scanned image.

The following describes how you may use your TWAIN compatible program to scan via the TWAIN interface. When you get familiar with the scanning, you may alternatively use other TWAIN compatible scanning programs or image-editing applications to do your scanning projects.

### Scan within your TWAIN compatible program:

1. Launch your TWAIN compatible program.



**Attention**

---

If you have more than one scanner or other imaging devices installed on your computer, you need to set this scanner as the default scanning source before you acquire the TWAIN program. Please refer to your TWAIN compatible program manual for more information about the settings.

---

2. Open the TWAIN window within your TWAIN compatible program. Please refer to your TWAIN compatible program manual for detailed information.

3. In the TWAIN window that opens, select **Sheet Feeder** as the Scan Type.

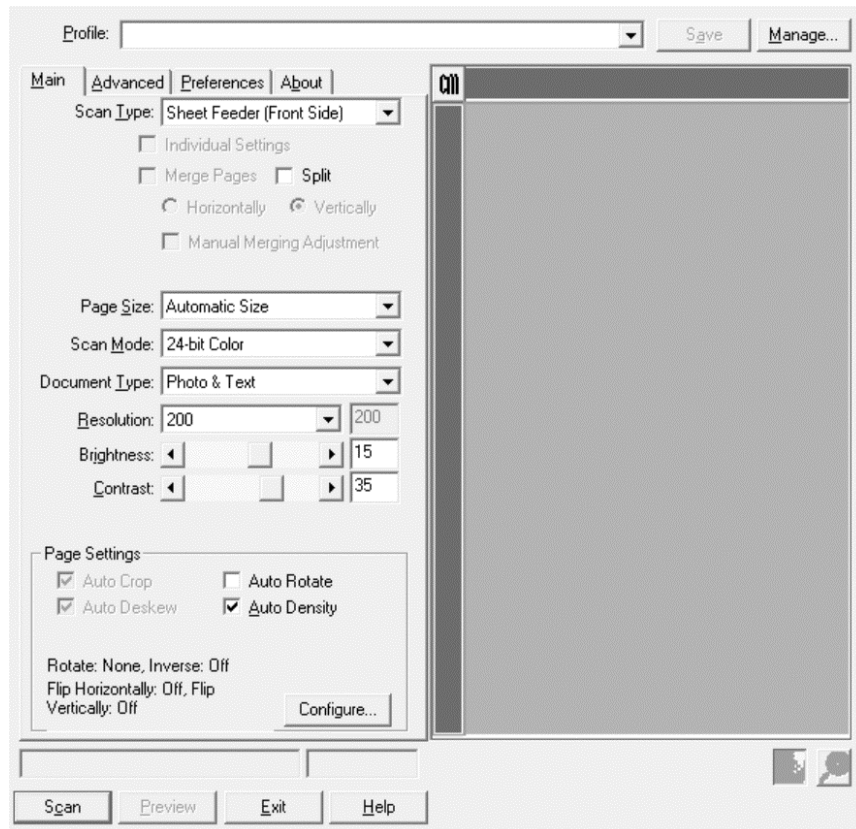

4. Adjust the scanning settings.
5. Insert the document face up into the scanner. Please allow the sensor to detect the edges of your document. The scanning starts immediately.
6. When the scan finishes, click the **Exit** button to close the TWAIN window. The scanned images are displayed in your TWAIN compatible program, and you may perform the image editing tasks.

Click the **Help** button within the TWAIN window for more information about the settings.

## Scanning from iDoc



### Attention

Before you start scanning from iDoc, click the **Exit** button to close the TWAIN window.



---

iDoc offers you quick access to the most frequently-used scanning functions. Scanning documents or images from this scanner is very easy. Follow the steps described below:

1. Do one of the following to open the **iDoc** window:
  - Click on the **iDoc** shortcut from the Windows **Start** menu > **All Programs**



> **Plustek iDoc** folder. (For Windows 8.1 users: Point your mouse cursor to the upper or lower right corner of your screen to open the **Charm** bar. Click on the **Start** charm, then click on the downwards arrow button in the lower left corner of the screen. The **Apps** screen will be shown. Move your cursor to the right edge of the screen to scroll right until you find **Plustek iDoc**, and then click on **iDoc**.) Right-click the  **iDoc** icon in the system tray, and select **iDoc** from the pop-up menu to display the main window.

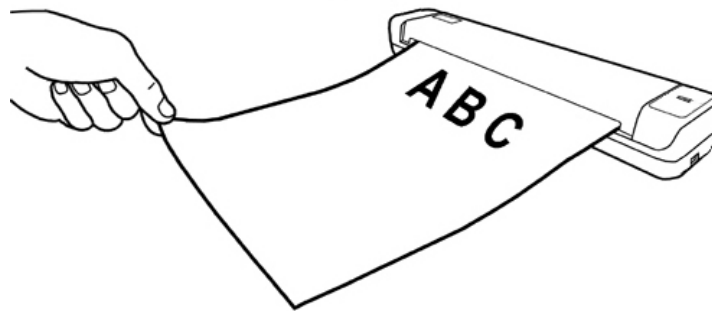

- Double-click the icon  on the desktop. Right-click the  **iDoc** icon in the system tray, and select **iDoc** from the pop-up menu to display the main window.

2. Insert the document face up into the scanner. Please allow the sensor to detect the edges of your document. The scanning starts immediately.

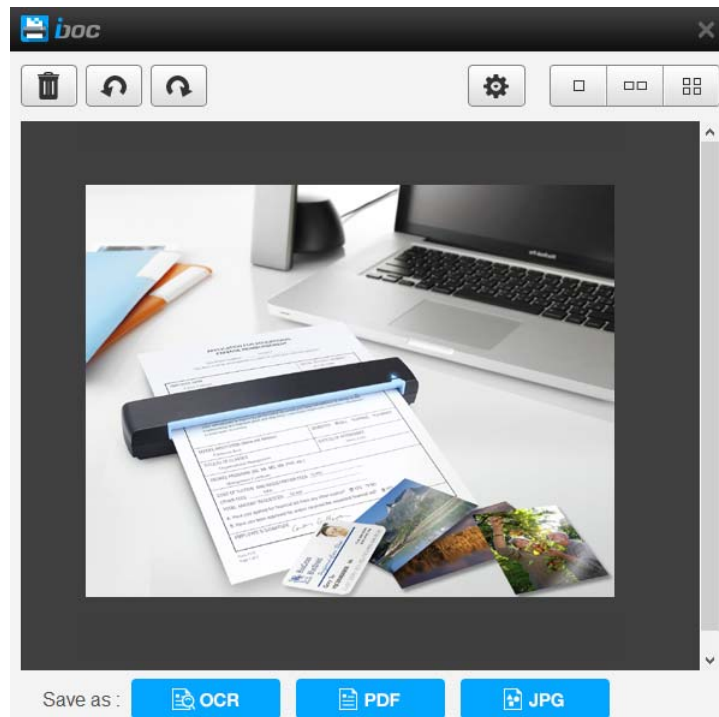

3. The scanned images are displayed in iDoc, and you may perform the image editing tasks.



4. Click on the ,  or  button brings you to the **Send to** dialog. Select the desired destination to send the scanned images.

Right-click the  **iDoc** icon in the system tray, and select **Help** from the pop-up menu for more information about the settings.

# Chapter III.

## Clean and Maintenance

Your scanner is designed to be maintenance-free. However, constant care and maintenance can keep your scanner working smoothly.

### Clean the Scanner

---

Paper powder, dust, ink and toner from paper being scanned may make the inner scanner dirty, which leads to poor image quality or document-feeding errors. Often clean your scanner could ensure your scanning better efficiency.



- Before cleaning the scanner, disconnect the scanner's USB cable, and then wait a few minutes for the glass and/or the inner scanner to cool to ambient temperature.
  - Wash your hands with soap and water before and after cleaning the scanner.
- 

### Cleaning Materials

Have the following cleaning materials ready to clean the scanner:

- **Cleansing cloth (or a cotton swab)**
  - **non-abrasive cleaner** - Isopropyl alcohol (95%). DO NOT use water.
- 



- Alternatively you can use glass cleaner or a neutral detergent for window cleaning to clean the scanner glass.
  - However, DO NOT use either of them to clean the scanner.
  - Use of other cleaning materials could damage your scanner.
-

## Clean Feed Roller and Glass

1. Open the scanner cover gently.

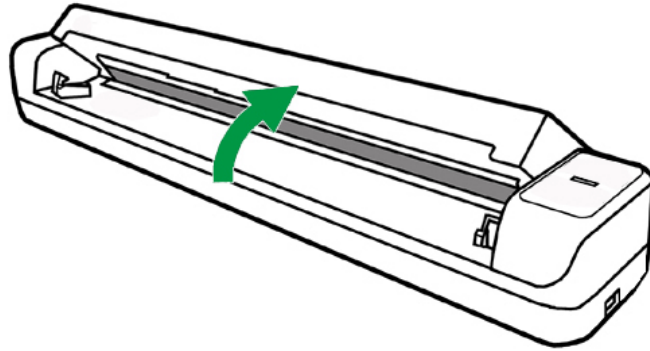

2. Wipe the Feed Roller from side to side and then roll it.
3. Clean the glass side to side. Repeat this until its entire surface is cleaned.

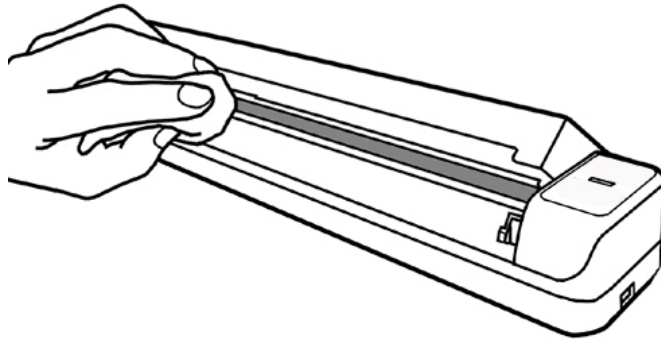

### Attention

Do not spray cleaner directly onto the scanner glass. Excess liquid residue may fog or damage the scanner.

4. Wait for cleaned areas to dry completely.
5. Press down the revolt bracket until it snaps back into place.

## Calibrating the Scanner

---

Calibrate the scanner if colors appear in areas that should be white, or colors of the scanned image and the original vary a lot. This allows you to adjust and compensate for variations that can occur in the optical component over time by its nature.

The following describes how to calibrate the scanner:

1. Insert the special calibration sheet face up into the page feed slot of the scanner.

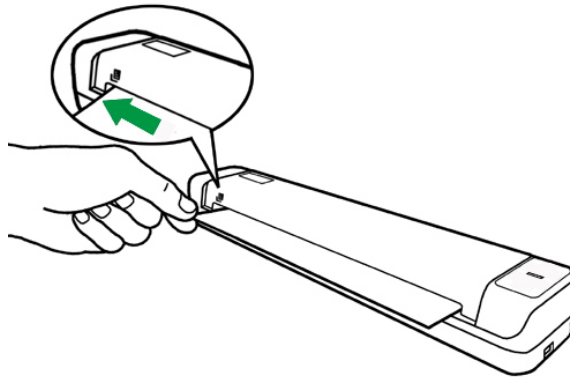

### Attention

Please insert the special calibration sheet included with the scanner. Alternatively you may also use any plain white sheet of paper sized in Letter size (8.5" x 11.69") instead; however, the calibration effect may be less good than the special calibration sheet.

---

2. Click **Start** > **All Programs** > **Your scanner model name** > **Calibration Wizard**. (For Windows 8.1 users: Point your mouse cursor to the upper or lower right corner of your screen to open the **Charm** bar. Click on the **Start** charm, then click on the downwards arrow button in the lower left corner of the screen. The **Apps** screen will be shown. Move your cursor to the right edge of the screen to scroll right until you find **Your scanner model name**, and then click on **Calibration Wizard**.)
3. Click **Next** from the Calibration Wizard that pops up and then click **Calibrate Now....**
4. Click on the **Start** button to begin the calibration process.
5. The scanner pulls the calibration sheet through the scanner, which completes this scanner calibration. After the calibration is complete, click **OK** and then click **Finish**.

## **Power Save**

---

To save power consumption, when the scanning process is finished, the scanner light source will turn itself off and the scanner will enter a lower-power mode without delay time.

## **Usage & Maintenance Tips**

---

To keep your scanner working smoothly, take a moment to review the following usage & maintenance tips.

- Do not insert any document into the scanner with small objects such as paper clips, pins, staples or any other fasteners attached.
- Do not insert damp, curled or wrinkled documents into the scanner for scanning. These documents can cause paper jams and possibly damage the unit.



# Chapter IV. Troubleshooting

If you encounter problems with your scanner, please review the installation and scanning instructions contained in this guide.

Before you ask for customer service or repair, please refer to the information in this chapter and consult our FAQ (Frequently Asked Questions) in which you can find useful self troubleshooting information. From the Windows **START** menu, point to **All Programs > Your Scanner Model Name**, and then click **FAQ**. (For Windows 8.1 users: Point your mouse cursor to the upper or lower right corner of your screen to open the **Charm** bar. Click on the **Start** charm, then click on the downwards arrow button in the lower left corner of the screen. The **Apps** screen will be shown. Move your cursor to the right edge of the screen to scroll right until you find **Your scanner model name**, and then click on **FAQ**.)

## Scanner Connection

The first step to take when troubleshooting connection problems with your scanner is to check all physical connections. The icon  , located on the Windows system tray, indicates if the scanner software is properly launched and the scanner and computer are communicating with each other.

Appearance	Status
	The program has been successfully launched and the scanner is connected with the computer, ready to scan mages.
	The scanner is not connected with the computer.
No Display	You have chosen to terminate the program, no matter the scanner is connected or disconnected with the computer.

# Appendix A: Specifications<sup>4</sup>

<b>Plustek MobileOffice S410 Plus</b>	
Image Sensor	CIS
Light Source	LED
Optical Resolution	600 dpi
Hardware Resolution	600 x 600 dpi
Scan Modes	Color: 48-bit Input; 24-bit Output Grayscale: 16-bit Input; 8-bit Output B/W: 1-bit
Scanning Speed	9 sec (Color Mode, 300 dpi, A4)
Scanning Area (W x L)	Maximum: 210 x 356 mm (8.5" x 14") Minimum: 12.7 x 12.7 mm (0.5" x 0.5")
Acceptable Paper Sizes (W x L)	Maximum: 210 x 356 mm (8.5" x 14") Minimum: 12.7 x 12.7 mm (0.5" x 0.5")
Acceptable Paper Weight (Thickness)	Paper: 50 g/m <sup>2</sup> to 120 g/m <sup>2</sup> Plastic card: Non-Embossed up to 1.0 mm
Daily Duty Scan (Sheets)	800
Power Supply	USB Power: 5V / 0.5A
Interface	USB 2.0
Net Weight	0.41 Kgs (0.91 Lbs)
Dimensions (W x D x H)	295 x 50 x 40.5 mm (11.61" x 1.97" x 1.59")

<sup>4</sup> Hardware specifications may change at any time without prior notice.



# Appendix B: Customer Service and Warranty

Please visit our website [www.plustek.com](http://www.plustek.com) for more customer service information. To avoid delays, please have the following information available:

- Scanner name and model number
- Scanner serial number (Located at the bottom of the scanner)
- Scanner DVD version and part number
- A detailed description of the problem
- Your computer manufacturer and its model number
- The speed of your CPU
- Your current operating system and BIOS (optional)
- Name of software package(s), version or release number and manufacturer of the software
- Other USB devices installed

## Service & Support Information (For EU country only)

---

Where appropriate, the period of availability of spare parts and the possibilities of upgrading products information. Please ask local distributors and suppliers for spare parts information and product upgrade information.

Information requested by relevant Implementing Measure. Please ask local distributors and suppliers for the related information of Implementing Measure test report.

Do not dispose anything of products before you ask local distributors and suppliers to get correct information for decreases of environmental impact with right methods and procedures.

If you want to disposals the product and/or an accessory, please ask local distributors and suppliers to get the contact information of nearest disposal manufactures.

If you have any maintenance inquiry, please ask local distributors and suppliers to get the contact information of nearest maintenance center in order to extend the product usage life time.

If you want to maintain and clearance the product, please ask local distributors and suppliers to get the right information of nearest stores.

## Statement of Limited Warranty

---

This Statement of Limited Warranty applies only to the options you originally purchase for your use, and not for resale, from an authorized reseller.

The manufacturer warranty includes all parts and labor, and is not valid without the receipt of original purchase. To obtain warranty service, you may contact the authorized dealer or distributor, or visit our website to check out the available service information, or send a request via E-mail for further help.

If you transfer this product to another user, warranty service is available to that user for the remainder of the warranty period. You should give your proof of purchase and this statement to that user.

We warrant that this machine will be in good working order and will conform to its functional descriptions in the documentation provided. Upon provision of proof of purchase, replacement parts assume the remaining warranty of the parts they replace.

Before presenting this product for warranty service, you must remove all programmes, data and removable storage media. Products returned without guides and software will be replaced without guides and software.

This Limited Warranty service does not provide for carry-in exchange when the problem results from accident, disaster, vandalism, misuse, abuse, unsuitable environment, programme modification, another machine or non-vendor modification for this product.

If this product is an optional feature, this Limited Warranty applies only when the feature is used in a machine for which it was designed.

If you have any questions about your Limited Warranty, contact the approved retailer from whom you bought the product or the manufacturer.

THIS LIMITED WARRANTY REPLACES ALL OTHER WARRANTIES, EXPRESS OR IMPLIED, INCLUDING, BUT NOT LIMITED TO, THE IMPLIED WARRANTIES OF MERCHANTABILITY AND FITNESS FOR A PARTICULAR PURPOSE. HOWEVER, SOME LAWS DO NOT ALLOW THE EXCLUSION OF IMPLIED WARRANTIES. IF THESE LAWS APPLY, THEN ALL EXPRESS AND IMPLIED WARRANTIES ARE LIMITED IN DURATION TO THE WARRANTY PERIOD. NO OTHER WARRANTIES APPLY AFTER THAT PERIOD.

Some jurisdictions do not allow limitations on how long an implied warranty lasts, so the above limitation may not apply.

Under no circumstances are we liable for any of the following:

1. Third party claims against you for losses or damages.
2. Loss of, or damage to, your records or data; or
3. Economic consequential damages (including lost profits or savings) or incidental damages, even if we are informed of their possibility.

Some jurisdictions do not allow the exclusion or limitations of incidental or

consequential damages, so the above limitation or exclusion may not apply to you.

This Limited Warranty gives you specific legal rights, and you may also have other rights that vary from jurisdiction to jurisdiction.

## **FCC Radio Frequency Statement**

---

This equipment has been tested and found to comply with the limits for a Class B digital device, pursuant to part 15 of the FCC rules. These limits are designed to provide reasonable protection against harmful interference in a residential installation.

This equipment generates, uses and can radiate radio frequency energy and, if not installed and used in accordance with the instructions, may cause harmful interference to radio communications. However, there is no guarantee that interference will not occur in a particular television reception (which can be determined by turning the equipment off and on), the user is encouraged to try to correct the interference by one or more of the following measures:

- Reorient or relocate the receiving antenna.
- Increase the separation between the equipment and receiver.
- Connect the equipment to an outlet on a circuit different from that which the receiver is connected.
- Shielded interconnect cables and shielded power cord which are supplied with this equipment must be employed with this equipment to ensure compliance with the pertinent RF emission limits governing this device.
- Consult the dealer or an experienced radio/TV technician for help if the conditions persist.
- Changes or modifications not expressly approved by the manufacturer or authorized service center could void the user's authority to operate this equipment.

This device complies with Part 15 of the FCC Rules. Operation is subject to the following two conditions: (1) this device may not cause harmful interference, and (2) this device must accept any interference received, including interference that may cause undesired operation.